



EPT20-15EHJ

Semi Electric Truck 1.5t

■ New Choice of Entry-level Electric Pallet Truck

EP EQUIPMENT CO.,LTD
www.ep-ep.com

▣ FEATURE

■ Light Weight, Great Capacity, Excellent Passingability:

1500KG capacity, light weight and compact size equivalent to hand pallet trucks.

■ Patented Design:

New Integrated Control Head Design, Easy & Comfortable Operation.

■ External Control System:

Patent designed external control system not only protects controller in place but also provides easy access for maintenance.

■ Operation :

Ergonomically-designed tiller head helps increase efficiency; Internal Charger for Easy Charging.

■ Safety :

Handy Emergency Disconnect Button & Durable Driving Unit ensure safety under any situation.

■ Maintenance :

Assembly Components, Easy for Diagnosis and Replacing.



Semi Electric Truck 1.5t

EPT20-15EHJ

Distinguishing mark			
1.1	Manufacturer		EP
1.2	Model designation		EPT20-15EHJ
1.3	Drive unit		Electric
1.4	Type of operation		pedestrian
1.5	Rated capacity	Q kg	1500
1.6	Load center distance	c mm	600
1.8	Load distance	x mm	883/946
1.9	Wheelbase	y mm	1152/1215
Weight			
2.1	Service weight (include battery)	kg	140
2.2	Axle loading, laden driving side/loading side	kg	540/1100
2.3	Axle loading, unladen driving side/loading side	kg	110/30
Types,Chassis			
3.1	Tyre type driving wheels/loading wheels		PU/PU
3.2	Tyre size, driving wheels (diameter*width)	mm	Φ210x70
3.3	Tyre size, loading wheels (diameter*width)	mm	2x Φ80x60 (Φ74x88)
3.4	Tyre size, caster wheels (diameter*width)	mm	
3.5	Wheels, number driving, caster/loading (x=drive wheels)	mm	1x /4
3.6	Track width, front,driving side	b ₁₀ mm	
3.7	Track width,rear,loading side	b ₁₁ mm	410 (535)
Dimensions			
4.4	Lift height	h ₃ mm	115
4.9	Height drawbar in driving position min./max.	h ₁₄ mm	715/1280
4.15	Lowered height	h ₁₃ mm	85(75)
4.19	Overall length	l ₁ mm	1588
4.2	Length to face of forks	l ₂ mm	438
4.21	Overall width	b ₁ / b ₂ mm	560(685)
4.22	Fork dimensions	s/ e/ l mm	50/150/1150
4.25	Distance between fork-arms	b ₅ mm	560/685
4.32	Ground clearance, center of wheelbase	m ₂ mm	35
4.34.1	Aisle width for pallets 1000 × 1200 crossways	Ast mm	1669
4.34.2	Aisle width for pallets 800 × 1200 lengthways	Ast mm	1869
4.35	Turning radius	Wa mm	1415
Performance data			
5.1	Travel speed, laden/ unladen	km/ h km/h	3.5/4
5.2	Lifting speed, laden/ unladen	m/ s	10mm/time
5.3	Lowering speed, laden/ unladen	m/ s	Controlable
5.8	Max. gradeability, laden/unladen		2/6
5.1	Service brake type		Electromagnetic
Electric-engine			
6.1	Drive motor rating S2 60 min	kW	0.65
6.2	Lift motor rating at S3 15%	kW	Manual Lifting
6.3	The maximum allowed size battery	mm	185/125/190
6.4	Battery voltage/nominal capacity K20		24/30
6.5	Battery weight	kg	9.5*2
Addition data			
8.1	Type of drive control		DC
10.5	Steering type		Mechanical
10.7	Sound pressure level at the driver's ear		74

- 1.The parameters in the table are of the standard model. For more information, please contact us.
- 2.The parameters are subject to change without notice.

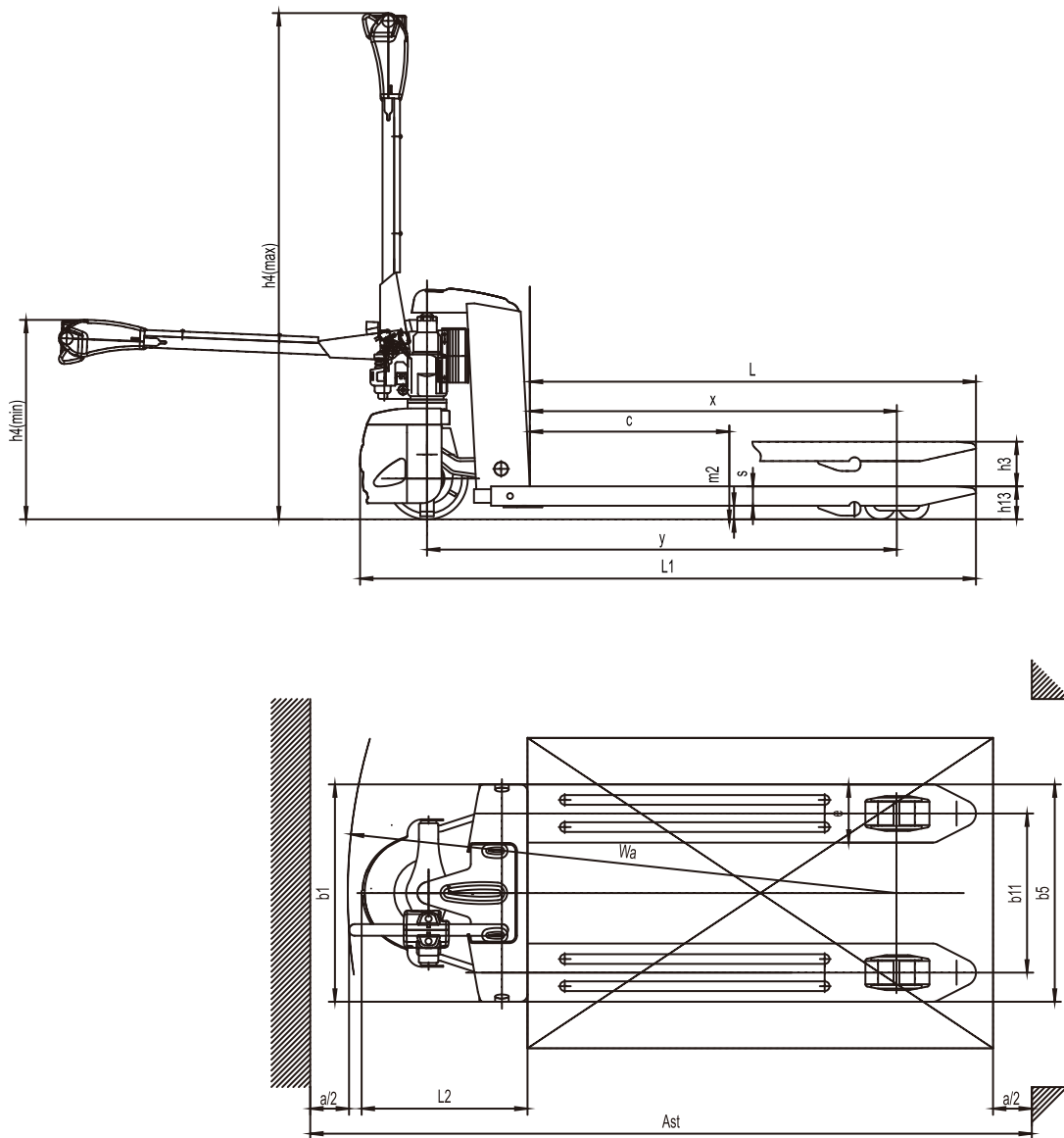

Option

Options	EPT20-15EHJ
Fork length	• 800/915/1000/1070/1100/1300/1400mm
Fork width	• 520/600mm
Single load wheel	•
Fork lowered height	• 40mm (Capacity ≤1000kg)
Driving wheel	PU wheel with Pattern
Scale	•