



EPT20-RAP

Low Order Picker 2.0t

Electronic Power Steering Makes Operation Easy & Fast;
AC Driving Motor Offers Stronger Power to Obtain Top Speed of 12KM/H;
Slowing-down in Curved Aisle Ensures the Smoothness and Stability.

EP EQUIPMENT CO.,LTD
www.ep-ep.com



FEATURE



Performance

- The innovative AC system offers strong power, accurate control, excellent performance.
- High strength vertical gearbox, longer working life.
- Low-noise but durable hydraulic unit, good quality cylinder as well as hose ensure the high reliability of hydraulic system.
- AMP connector and durable electric wires greatly reduce malfunctions of components.
- High speed (Up to 12km/h unladen), High Efficiency of Material Handling Operations.



Safety

- Safety foot switch avoids operators from misoperation.
- Automatic braking and reverse current braking when foot switch is off or travel switch is neutral.
- Emergency disconnecter will cut off power source to avoid accident when truck goes out of control.
- The function of skidproof brake avoid the truck skidding down when truck goes out of control or travelling on grade.
- Dual-monitoring power steering.

Operation

- With the new design of ergonomical tiller head, all buttons can be reached conveniently & comfortably.
- With backrest cushion, spacious operation room and vibration absorber pedal, the operator feels more comfortable.
- Side-open battery compartment design for easy replacement and maintenance.
- Coast control function, convenient for order picking.
- Electric power steering, smooth & comfortable (EPS).

Maintenance

- AC traction motor, maintenance free.
- Hour meter and battery indicator remind the operator of battery charging.
- Easily remove the back cover by only losing two bolts; Access to all key components for inspection, maintenance and replacement.
- Vertical motor makes the inspection & service much more convenient.
- Control system allows easy trouble-shooting.
- Low voltage lift cut off design protects the battery.

Low order picker 2.0t

EPT20-RAP

Distinguishing mark					
1.1	Manufacturer			EP	
1.2	Model designation			EPT20-RAP	
1.3	Drive unit			Electric	
1.4	Type of operation			standing	
1.5	Rated capacity	Q	kg	2000	
1.6	Load center distance	c	mm	600	1200
1.8	Load distance , centre of drive axle to fork	x	mm	980	1860
1.9	Wheelbase	y	mm	2161	3041
Weight					
2.1	Service weight (include battery)		kg	940	1050
2.2	Axle loading, laden driving side/loading side		kg	1200/1740	1210/1840
2.3	Axle loading, unladen driving side/loading side		kg	780/160	790/260
Types,Chassis					
3.1	Tyre type, driving wheels/loading wheels			PU/PU	
3.2	Tyre size, driving wheels (diameter*width)		mm	Φ230x90	
3.3	Tyre size, loading wheels (diameter*width)		mm	Φ85x70 / Φ83x115	
3.4	Tyre size, caster wheels (diameter*width)		mm	Φ180x65	
3.5	Wheels, number driving , caster/loading (x=drive wheels)		mm	1x +1/4 / 1x +1/2	
3.6	Track width, front,driving side	b ₁₀	mm	468	
3.7	Track width,rear,loading side	b ₁₁	mm	370/430/515	
Dimensions					
4.4	Lift height	h ₃	mm	120	
4.8	Seat height/standing height	h ₇	mm	166	
4.9	Height drawbar in driving position min./max.	h ₁₄	mm	1220	
4.15	Lowered height	h ₁₃	mm	85	
4.19	Overall length	l ₁	mm	2516	3770
4.20	Length to face of forks	l ₂	mm	1366	
4.21	Overall width	b ₁ / b ₂	mm	800	
4.22	Fork dimensions	s/ e/ l	mm	55/170/1150	55/170/2400
4.25	Distance between fork-arms	b ₅	mm	540/600/685	
4.32	Ground clearance, center of wheelbase	m ₂	mm	30	
4.34.1	Aisle width for pallets 1000 × 1200 crossways	Ast	mm	2568	3967
4.34.2	Aisle width for pallets 800 × 1200 lengthways	Ast	mm	2768	3967
4.35	turning radius	Wa	mm	2348	3227
Performance data					
5.1	Travel speed, laden/ unladen		km/ h	9/12	
5.2	Lifting speed, laden/ unladen		m/ s	0.026/0.034	
5.3	Lowering speed, laden/ unladen		m/ s	0.025/0.021	
5.8	Max. gradeability, laden/unladen			8/13	
5.10	Service brake type			Electromagnetic	
Electric-engine					
6.1	Drive motor rating S2 60 min		kW	2.5	
6.2	Lift motor rating at S3 15%		kW	0.84	
6.3	The maximum allowed size battery		mm	740*350*620	
6.4	Battery voltage/nominal capacity K5			24/360	
6.5	Battery weight		kg	330	
Addition data					
8.1	Type of drive unit			AC	
10.5	Steering type			Electronic	
10.7	Sound pressure level at the driver's ear			74	

- 1.The parameters in the table are of the standard model. For more information, please contact us.
- 2.The parameters are subject to change without notice.

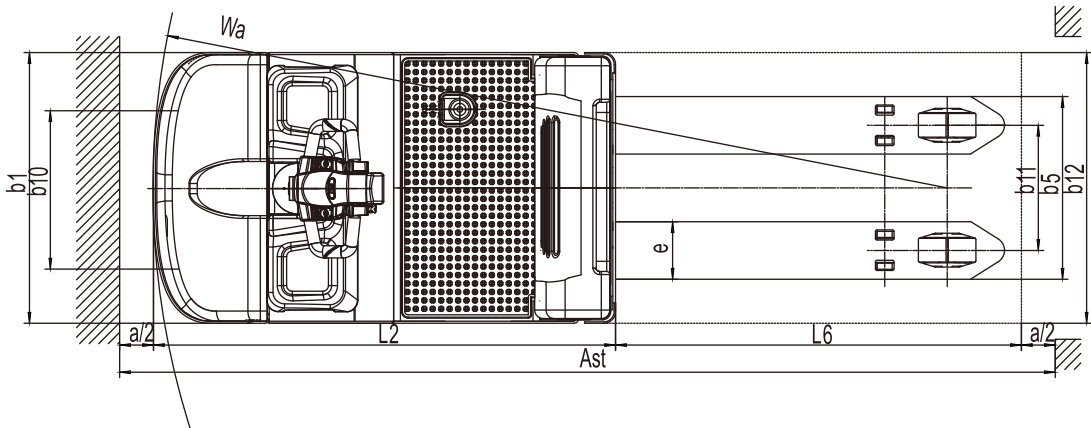
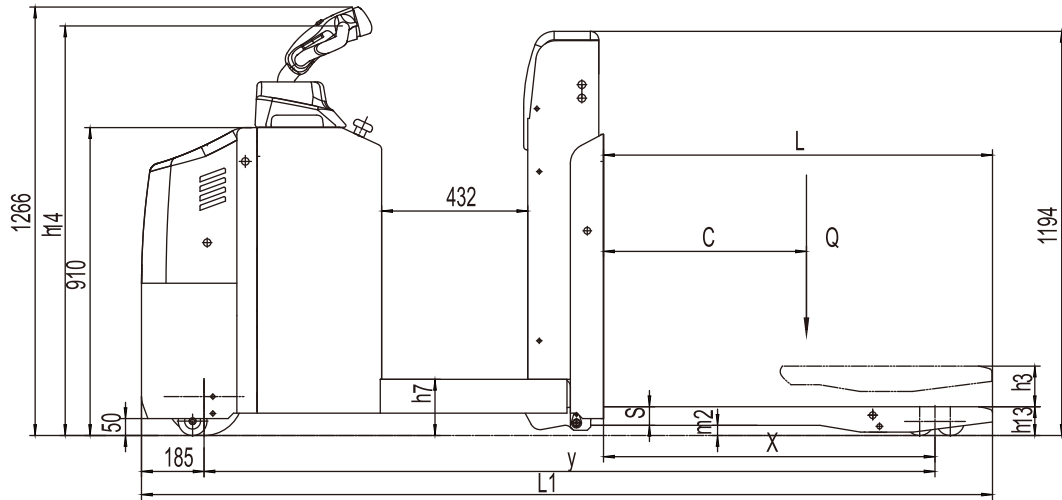

Option

Options	EPT20-20RAP
Fork length	•1150/2400mm
Fork width	•540/685mm
High capacity battery	•480Ah
Cold storage	•